

Modular 1U 24 Port Panel

Shielded

Application/Product Description

The HTC Series 1U 24 Port Modular patch panel has been developed to allow for simplistic installation. It accepts HTC compatible Keystone jacks. It Features a folding rear cable manager with cable tie points that simply snaps into place without the need for extra tools or manpower.

Features and Benefits

- Plastic Free Packaging
- Detachable, Folding Cable Manager
- Ideal for Shielded or Unshielded Requirements
- 1U 24 Ports
- Compatible with 19 Inch Mounting Profiles

Standards Compliance

- RoHS Compliant

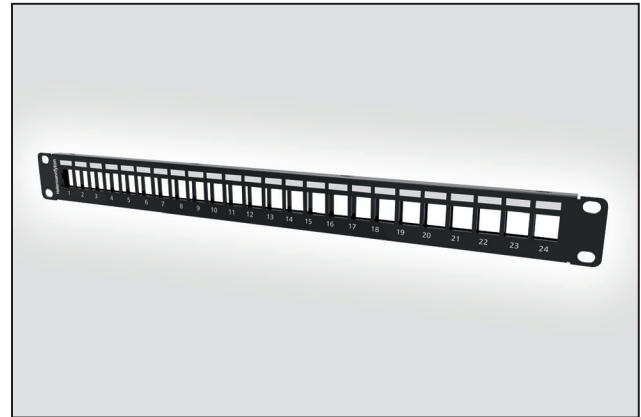

Modular Patch Panel (front view)

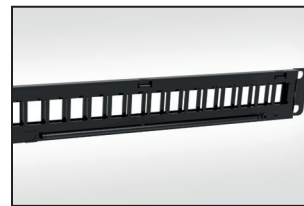

Modular Patch Panel (rear view)

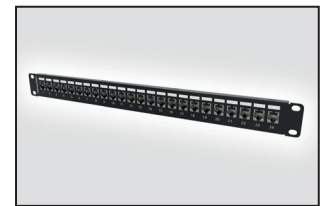

Loaded Modular Patch Panel

Technical Data

Operating Temp	-10°C to 60°C		
Storage Temp	-40°C to 68°C		
Humidity	10% to 90% RH (non-condensing)		
Materials	Cold Rolled Steel, Black Powder Coating		
Dimensions (mm)	W	D	H
	482.5	10.1	44

TYPE	Description
HTC-XXS-PPF241U/BK	Modular 1U 24 Port Shielded Patch Panel Inc. Rear Cable Manager

Compatible Jack	HTC-C6AS-KJ12
-----------------	---------------

Technical Diagrams

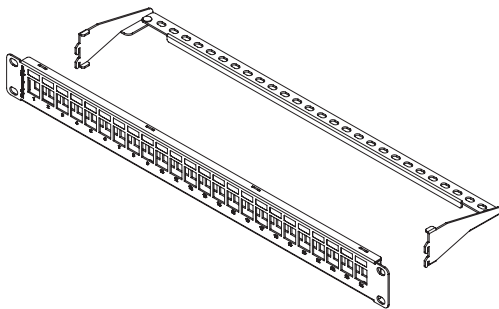

Modular Patch Panel and Rear Cable Management

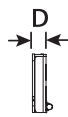

Side view

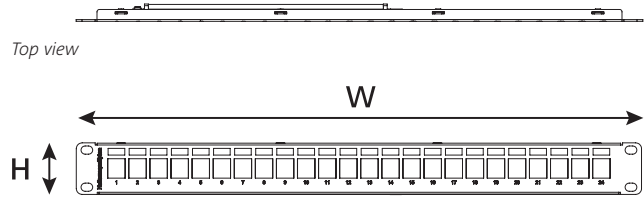

Front view