



- Provides Up To 4 Cat6 or 4 Cat5E Ports
- Support 'To The Desk' Installations
- 25 Year System Warranty

Product Description

RapidNet from HellermannTyton is the unique, pre-terminated and pre-tested solution that offers uncompromised performance and quality.

RapidNet can reduce installation time by up to 85% and is designed to meet the exacting standards of mission critical installations where network down time and poor systems performance is not an option.

The Cassette to Pod option is designed to support any 'to the desk' installation in various commercial environments including offices, trading floors and schools.

The Pod can be mounted to the desk, snapped directly into a floor box aperture or used beneath a railed floor on a consolidation point or similar configuration.

The 4 Port RapidNet Pod is manufactured with either 4 Cat6 or 4 Cat5E Alpha Snap Outlets, providing a maximum of 4 ports per pod.

Features and Benefits

- Exceeds ISO/IEC 11801 and ANSI/TIA/EIA 568-C.2 Cat6 and Cat5E performance standards
- 4 port capacity
- Available in 2 and 4 port options (where split Pod option is available)
- Manufactured to exacting ISO 9001 quality standards
- RoHS compliant - lead free
- Backward compatible with Cat5E, Cat5
- Fits into standard floor boxes

Product Description	Ordering Code	UNS Number
RapidNet Cat6 - Cassette to Pod - 4 Port	RN04UC6-CAPOXX-xx.xm	Available on request
RapidNet Cat5E - Cassette to Pod - 4 Port	RN04U5E-CAPOXX-xx.xm	Available on request

Technical Description

The RapidNet Pod can also be used as a consolidation point under the floor or within a ceiling void, adding more flexibility to any network infrastructure.

Robust and attractive, the white ABS plastic pod is designed to clip into standard floor boxes via a suitable floor box mounting plate. The rounded edges alleviate snagging during the pulling and fixing stages of an installation. For protection during delivery, the pod is inserted within the cable reel and up to 5 metres of the cable can be protected by a black copex sleeve (on request).

During installation the Pod can be slipped off the reel ready to be pulled into position. Designed to accommodate up to 6 shuttered outlets, the pods can be split into two or three looms from the main RapidNet cable with two or three outlets in each pod.

All RapidNet Cat6 and Cat5E cables are made with LSOH material, complying with the latest European Fire ratings.

RapidNet terminations are tested to exceed all ISO/IEC 11801 and ANSI/TIA/EIA 568-C.2 Cat6 and Cat5E standards.

Dimensions and Product Construction Specification

Ordering Code	Height (Pod)	Width (Pod)	Depth (Pod)
RN04UC6-CAPOXX-xx.xm	59.33mm	183.88mm	65.73mm
RN04U5E-CACOXX-xx.xm	59.33mm	183.88mm	65.73mm

- Jack life min. 1000 insertions
- Disaster Recovery - Terminated and ready for use
- Cabinet to Floor Box - Adapter plates available for most floor boxes
- Sporting Events - Re-usable for different events
- Business As Usual Refurbishment - 5pm - 9am after hours working
- Under Floor and Ceiling Voids - Cabinet to Consolidation Point
- Installation time saving of up to 85%
- Covered by UK Patent 2398437, UK Patent 2410383, US Patent 7375282

Applications Supported

The RapidNet Cat6 and Cat5E solutions are designed to support any voice and data cabling system that is capable of running over respective systems and are backwards compatible with existing Cat5E, Cat5 and voice network infrastructure.

Technical Drawings

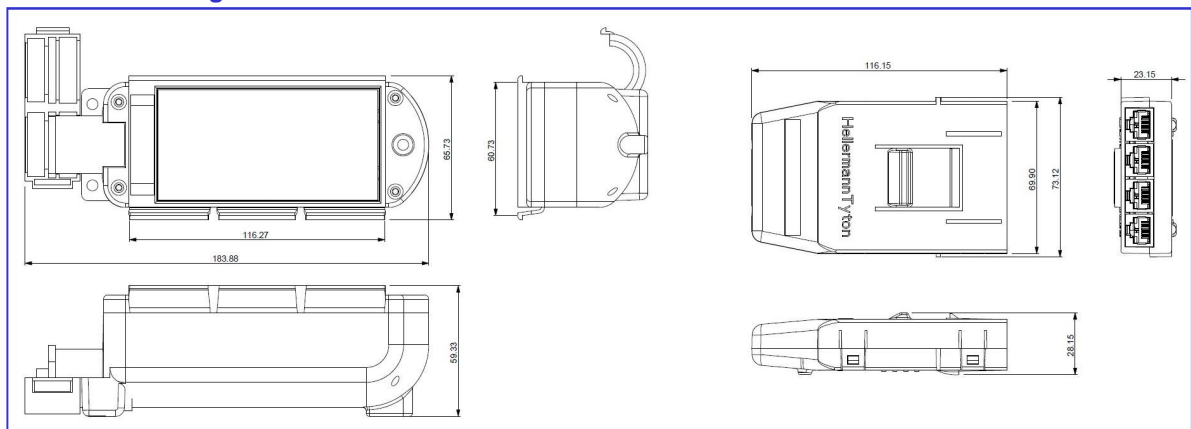

Connecting Hardware Test

Tested from: 1 MHz
 Tested to: 100 MHz
 Standard: ISO/IEC 11801 and
 ANSI/TIA/EIA 568-C.2
 Limits: Cat5E - Connector

Connecting Hardware Test

Tested from: 1 MHz
 Tested to: 250 MHz
 Standard: ISO/IEC 11801 and
 ANSI/TIA/EIA 568-C.2
 Limits: Cat6 - Connector

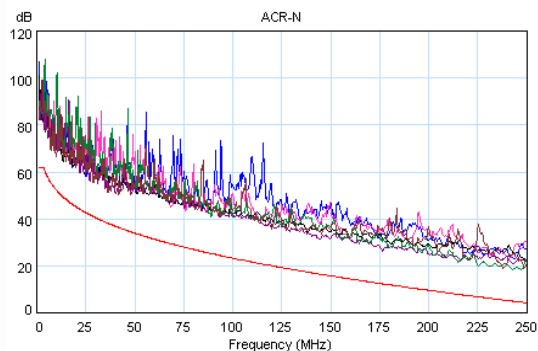
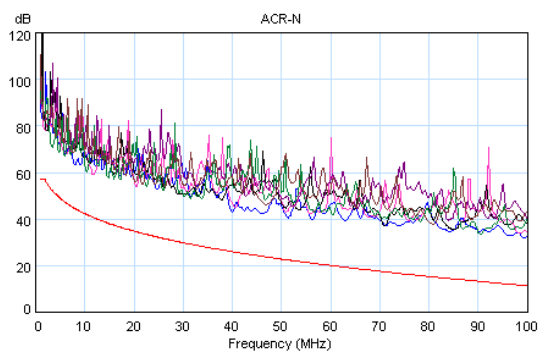
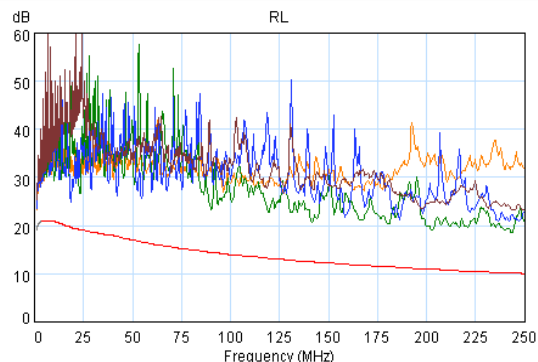
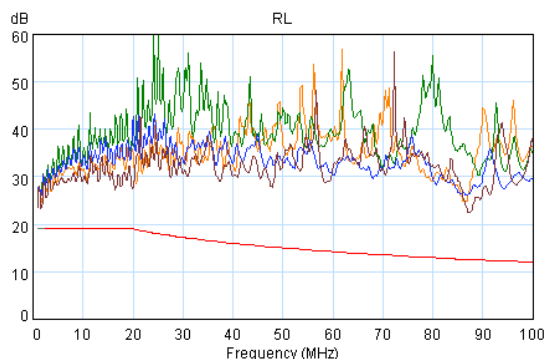
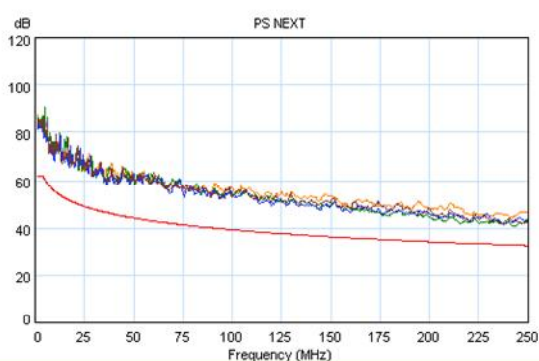
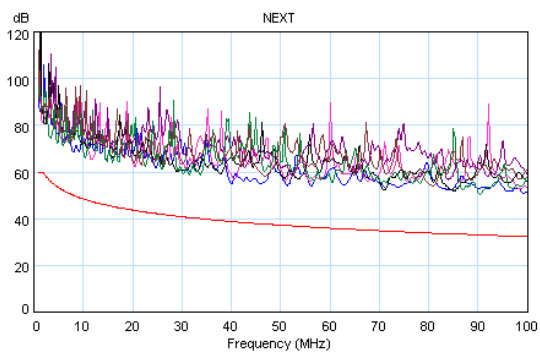

Tel: +44 (0) 1604 707420
 Web: www.htdata.co.uk
 Email: sales@htdata.co.uk