

HellermannTyton

TELECOMS

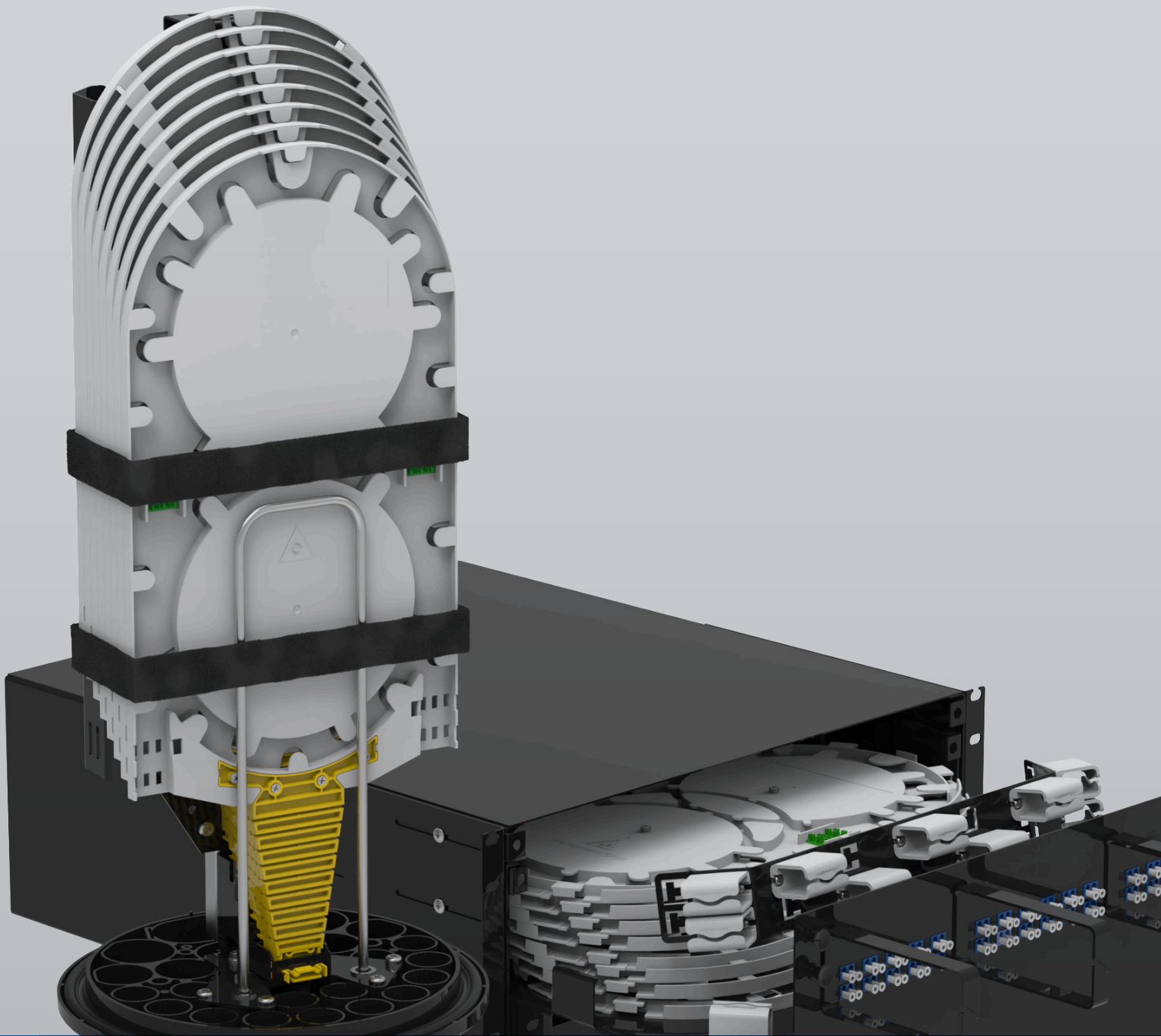

Hollow Core Fibre Connectivity

Better Technology through Innovation

MADE TO CONNECT

Next Generation Performance with Hollow Core Fibre Connectivity

Hollow Core Fibre (HCF) represents a step change in optical performance for data centre interconnect and long-reach external networks, transmitting light through air rather than glass to significantly reduce latency and signal distortion.

Operating far closer to the speed of light in a vacuum, HCF delivers up to 50 percent lower latency than conventional singlemode fibre, making it a compelling foundation for next generation data centre and hyperscale networks.

Through purpose-designed connectivity solutions and deep optical infrastructure expertise, HellermannTyton ensures that the unique performance benefits of HCF are preserved from installation to long-term operation.



Why Hollow Core Fibre?

Hollow Core Fibre (HCF) technology is rapidly reshaping the landscape of high performance optical infrastructure.

Unlike traditional solid core fibres, HCF guides light through an air filled core, enabling significantly lower latency, reduced attenuation, and dramatically minimised nonlinear effects. This technological breakthrough allows light to propagate along the fibre at speeds approaching those realisable in a vacuum. As the light travels much closer to 3×10^8 m/s, the speed of light in a vacuum, the fibre can deliver between a 30% and 50% improvement in latency when compared to standard singlemode silica fibres. This, in turn, provides numerous benefits to both hyperscalers and more traditional data centre providers alike.

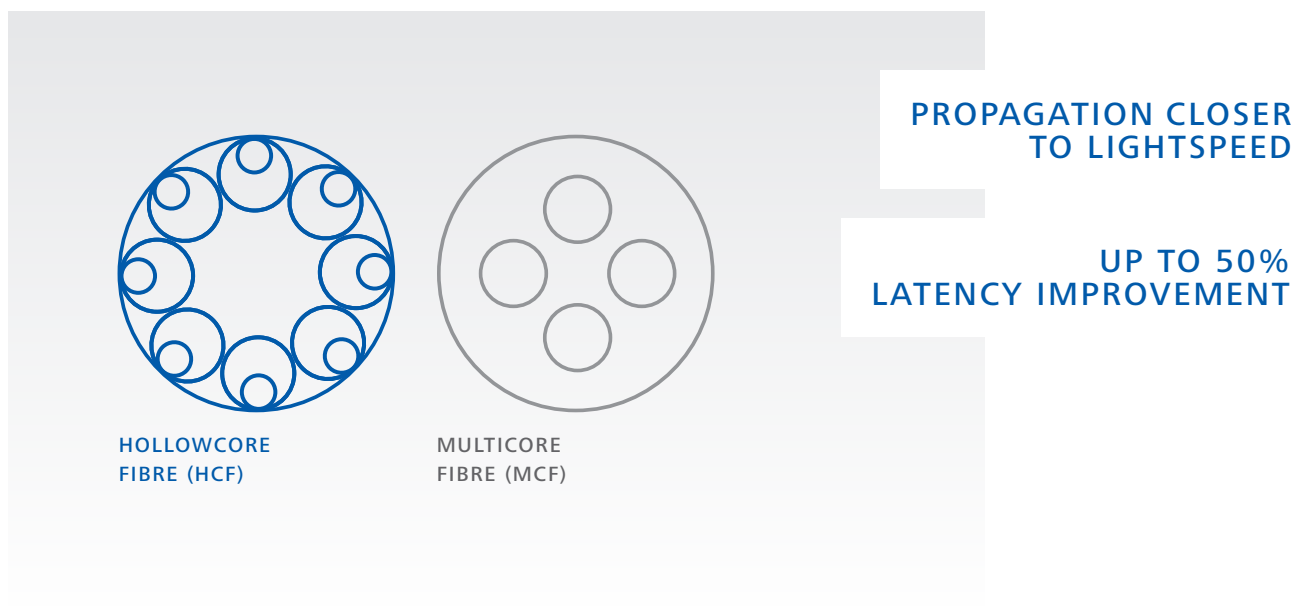

As data intensive applications continue to expand, from real time financial trading to cloud hyperscale interconnects, we are seeing an increase in HCF being deployed in environments where microseconds, or kilometres, matter. Its reduced light-material interaction not only improves signal integrity but also allows for higher power handling, broader spectral operation, and enhanced stability in demanding network conditions. These characteristics make HCF ideal for modern telecommunications, next generation data centres, precision sensing systems, and emerging high speed transport networks.

 Learn more about Hollow Core Fibre

Our fibre connectivity solutions are compatible with almost any fibre network design. If you can't find the exact product to meet your needs, don't worry our extensive range will have the right solution for you.

Scan for more applications online.

The Changing Reality of Digital Infrastructure

Why power constraints, AI demand and latency are redefining where digital infrastructure can scale.



The global explosion of data centre deployments has had a significant impact on the availability of electricity and real estate.

Add to this the demands of artificial intelligence and the compute required for the training of large language models (LLMs) and other AI based technologies such as agentic AI. Distributing this compute across society to the locations where it is needed, all whilst ensuring sufficient energy and real estate, becomes a proverbial jigsaw without a picture.

Meeting each of these demands from a single location, let alone the additional requirements associated with data sovereignty and resiliency, which counter the single point of presence approach, is becoming increasingly challenging.

Building where there is power might mean there are no customers, while building where there is cheap land might mean that the distances between POPs are too large, and latency excludes them as viable options.

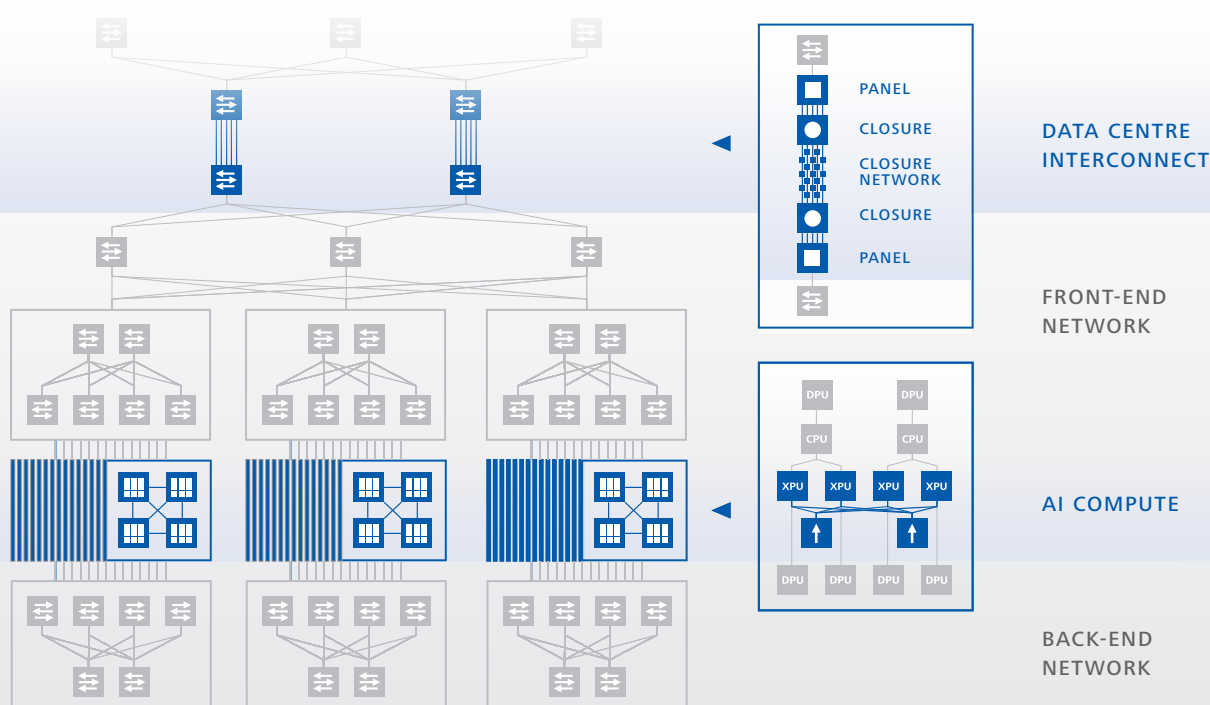

Extending Distance Without Compromise

HCF is being hailed as a huge game changer to cloud providers and operators (CPO's), since it elegantly removes a significant obstacle, the maximum distance between DC's. What was once limited to 100 km between two resilient data centres for a CPO can, with the use of HCF, be increased to 130–150 km, opening up access to better electricity supply, more suitable real estate, as well as a greater number of potential customers.

Support for DWDM Technology

In addition to the improved latency of HCF, its ability to deliver more power, as well as offering support for DWDM technologies, further increases wavelength utilisation, bit-stream densification, and distances between in-line amplification positions.

Built for Terabit-Scale Connectivity

Using coherent optics at 400 Gbps and beyond, in conjunction with DWDM technologies over HCF fibres, can enable single fibre delivery of multiple terabits of data. This, in conjunction with HCF-based fibre cables, ensures the data centre interconnect characteristics required now and in the future are well and truly met.

Beyond Hyperscale

Of course, it is not just the demands of the CPOs that are being met, as they extend their remit beyond simple compute into real estate, power generation, and the deployment of their own connectivity infrastructure. Smaller operators, and even single institutions, will realise huge gains through the use of HCF.

Scaling Today for Tomorrow's Demands

Today's regional, local, and international carriers are only making small gains in deploying dark HCF, preparing them to support future high speed, low latency demands. Conventional singlemode fibre will still support 800 Gbps today, along with DWDM, but distance is another matter. Deploying duct bundles to allow for future growth towards HCF, or deploying HCF today, either for smaller DCs to interconnect over, or to allow CPOs to consolidate their last mile connections over existing HCF infrastructure, would certainly be a step in the right direction.

The Next Challenge

This incredible leap in DCI capability does not come without some challenges, which we will cover next, but as we see the scale and complexity of AI based compute increase, so does the desire to increase east west traffic, essentially increasing the number of connections between these silicon neurones.

Fibre Design to Real-World Deployment

Bridging advanced Hollow Core Fibre engineering with deployment-ready infrastructure to deliver reliable, high-performance connectivity at scale.

Understanding HCF Design Constraints

The internal structure of HCF has undergone several evolutionary steps, but the technology appears to be gravitating towards what is referred to as a double nested anti-resonant nodeless fibre, or DNANF.

The basics are a number of nested tubes, or straws, which are drawn from a pre-form similar to a single or multi mode fibre. The biggest difference is that there is air between these straws, and the forces required to collapse the straw are much less than those of a more conventional fibre. This distinction leads to a fundamental difference between HCF and SMF, the minimum bend radius, or MBR. The typical MBR of a singlemode fibre, depending on the type, is between 10 mm and 30 mm. The typical MBR of an HCF is in the region of 50 mm to 75 mm. Whilst this seems excessively large when compared to an SMF fibre, the reasons become obvious once you understand the construction of the fibre. It should be noted that it is possible to bend an HCF fibre to dimensions comparable to an SMF fibre, but this will dramatically reduce the fibre's mean time to failure, or MTTF.

With the huge significance placed on the availability of a CPO's data centres, and the data they process, even before we consider how AI will evolve in the future, designing the DCI with parameters that will cause it to prematurely degrade and fail seems counterintuitive.

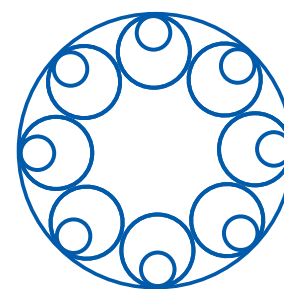

HOLLOWCORE
FIBRE (HCF)

Enabling HCF in the Real World

HellermannTyton has been integral in the deployment of several high profile HCF networks for an industry defining CPO, and has used its extensive experience to ensure that today's HCF deployments are not the cause of failure in the next generation of backhaul and DCI connectivity.

To support these next generation optical links, infrastructure must evolve alongside the fibre itself. This brochure introduces two purpose built HCF connectivity solutions, engineered to preserve the unique performance advantages of HCF from the point of installation through long term field operation:

- **HCF Dome Closure** - designed for robust outdoor or underground network environments where mechanical protection, environmental sealing, and minimal handling induced loss are essential.
- **HCF 4U 19" Panel** - optimised for data centre and rack based deployments requiring dense, low latency, and modular cross connects.

Together, these products bridge the gap between cutting edge fibre and real world deployment, ensuring that the full speed, stability, and precision of HCF is delivered all the way to the network edge. They provide operators, integrators, and infrastructure designers with reliable, scalable platforms to accelerate the adoption of HCF enabled ultra fast optical networks.

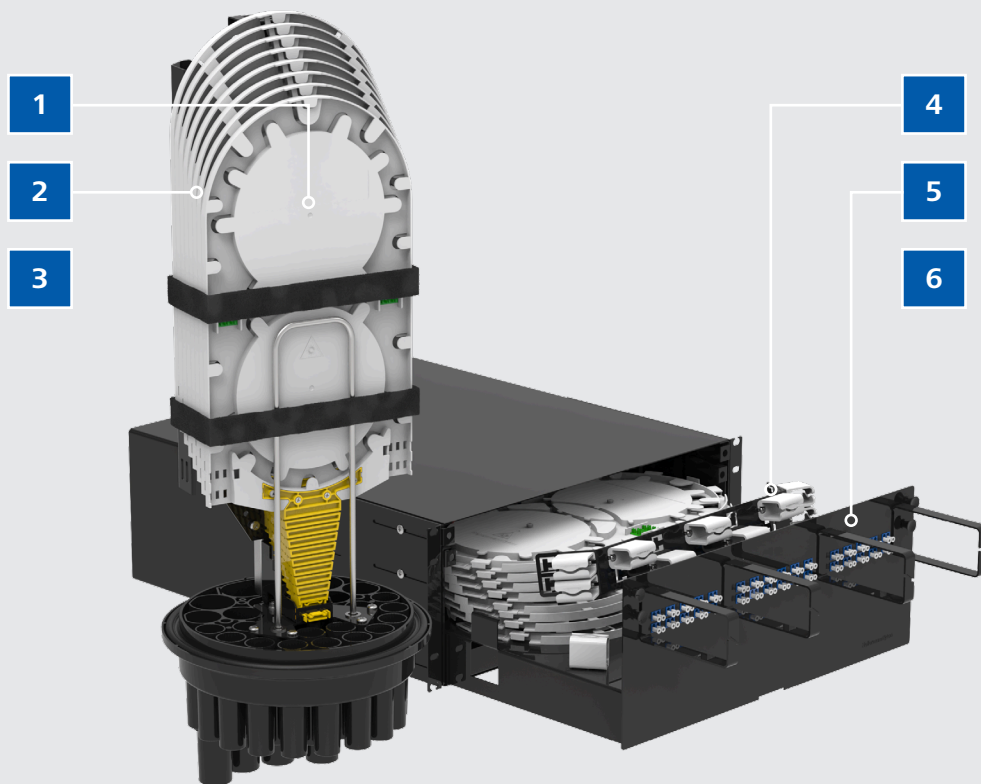

Key Features

1

Maximised Life Expectancy

Trays are engineered to securely manage HCF cable while maintaining a minimum 75 mm bend radius, reducing mechanical stress.

2

Up to 10m Fibre per tray

8 HCF trays per node hold up to 10m of fibre per tray to support gas-ingress during splicing and maintenance.

3

Fibre Integrity and Safety

Integrated tray support provides stability for the trays during splicing. Reliable watertight sealing and resistance to vibration.

4

Pigtail Management

Lateral patch managers and a fibre bracket control HCF routing and support splice-on pigtails for secure, organised terminations.

5

Patch Cord Management

Front-mounted rings support patch cords, providing controlled routing, strain relief and reduced risk of signal loss or disconnection.

6

Positive Fibre Management

4U sliding chassis enables controlled fibre routing, seamless direction changes, and smooth transition between HCF and SMF.

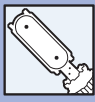

UFC Hollow Core Fibre Dome Closure

C Length UFC Dome Closure, 8 Hollow Core Fibre Trays and Loop Storage Basket

The HellermannTyton UFC C Length Dome Closure is provided with a polypropylene base. The base configuration of 28 round ports and 2 oval ports supports a cable diameter range of 4.8mm to 29.0mm when using HellermannTyton Cablelok mechanical seals.

The mounting and support system is manufactured from stainless steel and polypropylene and is fitted with eight Hollow Core Fibre Management trays. The position of the port entries and the mounting system allows for ease of access and traceability of the fibres on to the tray. Each tray is mounted on a flexible polypropylene hinge providing a single pivot point allowing the trays to be positioned for easy access to all eight tray positions.

Each Hollow Core Fibre Management tray is fitted with 2 x 3A splice bridges providing a maximum splice capacity of 24 x 3A splices per tray.

The closure is supplied with a loop storage basket which is positioned at the rear of the splice management trays and over the oval ports on the base of the closure providing storage for management of fibre loops for loop through applications.

The Hollow Core Fibre Management Tray has been designed to manage Hollow Core Fibre whilst maintaining a 75mm minimum bend radius the overall dimensions of the tray are 383 x 210 x 9mm. The tray is manufactured from PC/ABS (polycarbonate/Acrylonitrile Butadiene Styrene) and finished to a high standard to eliminate the risk of snagging and microbends. All retaining tabs on the tray have radius edges and rounded corners where fibre may pass.

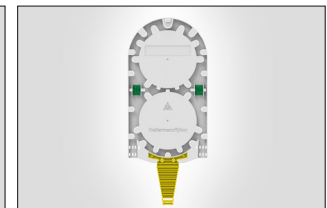
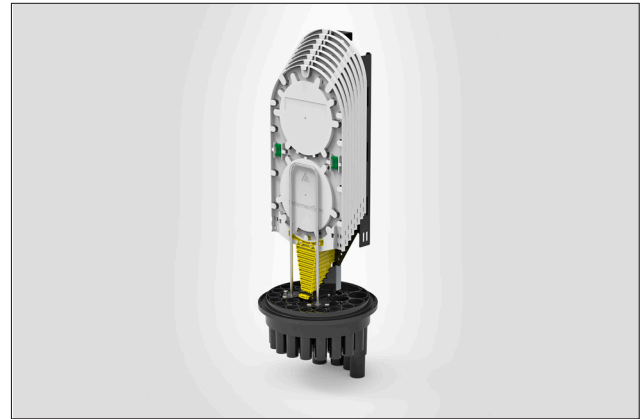

Top: UFC Hollow Fibre Dome Closure.
Bottom Left: UFC Closure shown with lid and clamp installed.
Bottom Right: Hollow Core Fibre Management Tray.



Key Features

- Maximum 192 3A fibre splices (double stacked)
- 28 round ports and 2 oval ports
- 8 Hollow Core Fibre Management Trays
- Loop storage basket for loop through applications
- Cablelok compatible for all port sizes
- Quick Release Clamp
- Optional flash test valve and/or grounding feed through

Technical Diagrams

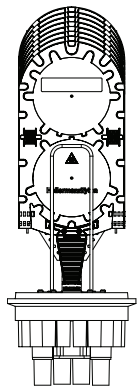

Front view.

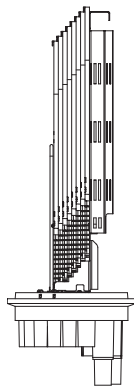

Side view.

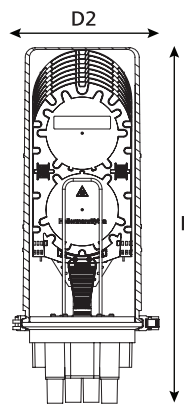

Cross section view with lid and clamp.

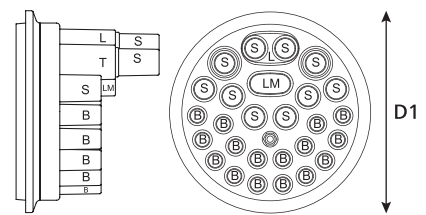

Base configuration.

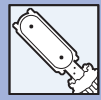

Mounting Bracket

MOBRA & Wall Mounting Bracket Kits

A range of mounting bracket kits are available for use with the HellermannTyton dome closures. The kits are designed to allow closures to be mounted in a pit using a Mobra Pit Arm or onto a Wall or Pole.

The mounting bracket is attached to the base allowing the cover to be removed and the closure to be worked on whilst in situ.

Key Features

- Available in Pole/Wall mounting configurations
- Enables in-situ access by allowing the cover to be removed
- Simple, robust designs for quick and easy installations
- Manufactured from zinc-plated mild steel / stainless steel

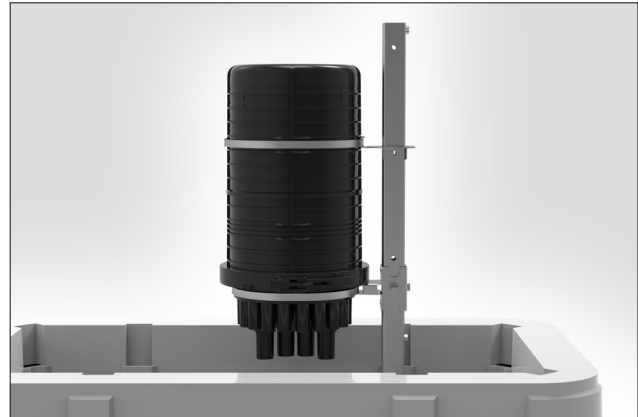

UFC mounted using a Mobra Pit Arm.

Microduct - Single

Direct Buried / Thick Walled / HDPE

HellermannTyton's Single Microduct (SP-G) is a thick walled duct manufactured from HDPE and is suitable for direct buried applications in the FTTx network including branching off from existing trunk routes. The microduct is available in a variety of different sizes ranging from 7mm to 25mm. Each duct has been designed with internal sliding ribs and is coated with HellermannTyton's G-Liner (low friction liner) to ensure an optimal air cushion for the fibre optic cable during the blowing in process.

Key Features

- Available in a broad range of diameters including 7/14, and 25mm
- Suitable for combination with sub-duct solutions
- Supplied on a wooden one-way spool which is optimised for transport and installation
- Transparent inspection windows show the presence of cables
- A wide range of colour options



Direct buried, thick walled, single microduct.

Microduct - Bundles

Direct Buried / Thick Walled / HDPE

HellermannTyton's Microduct bundles (SRV-G) are a thick-walled duct manufactured from high quality HDPE material for Direct Buried (DB) applications which include, mole ploughing, open trench, slot cutting (Incl. narrow and micro trenching).

The SRV-G tube bundles are available in a variety of different sizes and can be mixed to create a combination of ducts to suit different network requirements.

To offer compatible end to end air blown ducted solutions, HellermannTyton manufactures its own in-house range of connecting and sealing elements.

Key Features

- Ideal for Direct Buried (DB) applications
- Optimised for long distance blowing
- Suitable for Push or Pulled installations
- Very Low Ovality
- >30 bar burst test
- Made from high quality HDPE
- Coated with G-Liner, HellermannTyton's Low Friction Liner

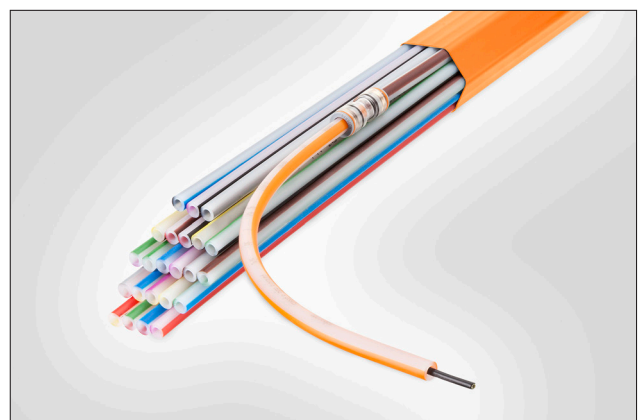

SRV-G 24 x 7mm.



4U 19' Fibre Panel

4U ODF Panel, 8 Hollow Core Fibre Management Trays, Panel Adaptor Bracket and Fibre Management Support

The HellermannTyton 4U 19" rack mountable sliding ODF panel is manufactured from powder coated mild steel.

The 4U panel is fitted with a Panel Adaptor Management Bracket which houses a maximum of 32 LC Duplex adaptors and additional cable management is provided by four ring cable managers on the front of the panel which support and hold cables in position.

Rear cable management is provided by a range of M20 cable glands and a series of cable and strength member anchoring points for a maximum of 8 cable entry/exit points.

The panel fibre management system consists of stainless steel management bracket, a polypropylene tray mounting system and a series of lateral patch cord managers. The trays are mounted on a polypropylene mounting system which is secured to the rear of the management bracket allowing the trays to be transposed and removed from the panel allowing fibre elements to be stored and managed in its base. The lateral patch cord managers are fitted on the front of the management bracket providing fibre management for Hollow Core Fibre elements as they are routed around the panel and onto the fibre management trays whilst maintaining a minimum 75mm bend radius.

The position of the eight Hollow Core Fibre Management trays allows them to be pivoted for ease of access during installation and maintenance. Each tray is self-supporting and is fitted with 2 x 3A splice bridges providing a maximum of 24 3A splices.

The Hollow Core Fibre Management Tray has been designed to manage Hollow Core Fibre whilst maintaining a 75mm minimum bend radius, the overall dimensions of the tray are 394 x 234 x 9mm. The tray is manufactured from PC/ABS (polycarbonate/Acrylonitrile Butadiene Styrene) and finished to a high standard to eliminate the risk of snagging and microbends. All retaining tabs on the tray have radius edges and rounded corners where fibre may pass.

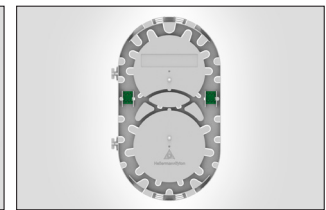
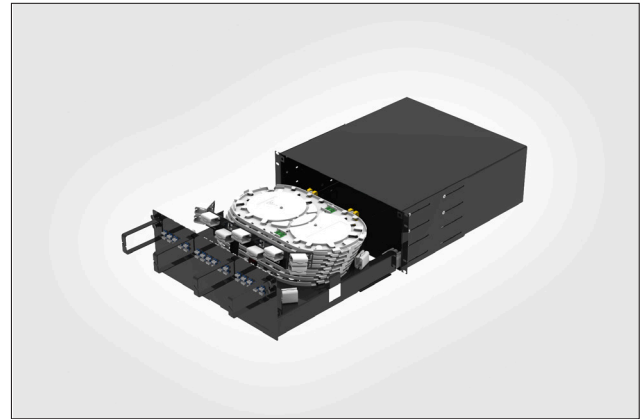

Top: 4U 19' Fibre Panel shown with tray open
Bottom Left: 4U 19' Fibre Panel shown closed.
Bottom Right: Hollow Core Fibre Management Tray.



Key Features

- Maximum 64 LC Duplex Connections
- Multiple Cable Entry Points
- Fibre Management System to maintain minimum 75mm bend radius
- Maximum Splice Capacity per tray
 - 3A Splice – 24 (double stacked)

Technical Diagrams

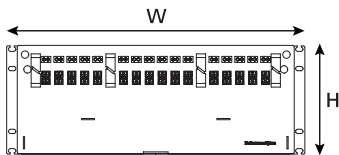

Front view.

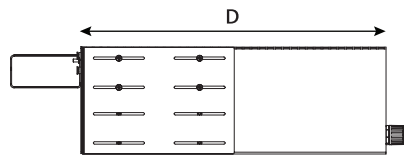

Side view.

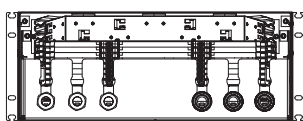

Back view.

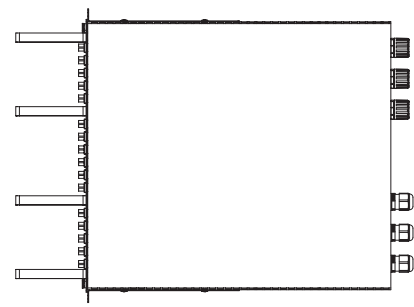

Top view.



GigaDuct

Fibre Raceway

GigaDuct is a robust, scalable fibre raceway system engineered to protect, organise and future-proof optical fibre cabling in data centre and critical network environments. Manufactured from halogen-free, flame-retardant material, it fully encloses fibres to guard against dust, debris and mechanical damage, while integrated bend-radius control helps preserve long-term network performance.

The comprehensive GigaDuct range includes straight ducts, elbows, tees, reducers, vertical and horizontal transitions, and optional covers, enabling flexible routing across any installation. Its modular, tool-free click-fit design allows fast installation, easy access for maintenance, and simple expansion as network demands grow. The result is a clean, professional cable pathway that reduces clutter, improves safety and supports efficient upgrades with minimal disruption. Innovative tool-free couplers enable rapid GigaDuct Fibre Raceway assembly and installation, reducing deployment time and labour costs without compromising long term stability and reliability.

It is available in a variety of sizes to suit any data centre configuration; 50mm, 100mm, 200mm and 300mm wide. This range ensures that you have the perfect fit for your specific needs, providing flexibility and adaptability for any data centre installation.

Constructed with precision, it provides a dedicated pathway that prevents cable congestion, minimises physical stress on fibres, and facilitates efficient cable management.

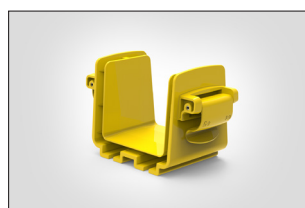
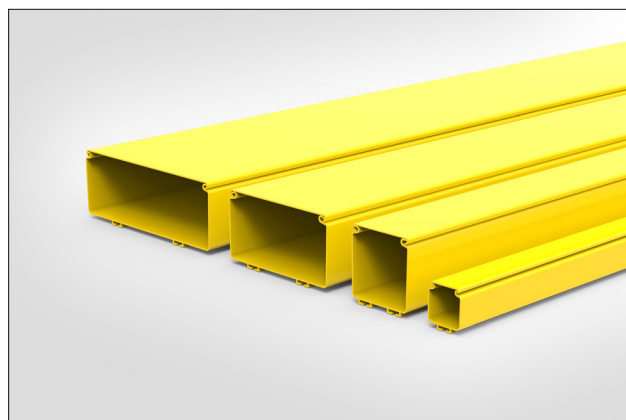

Top: Straight Duct 300mm, 200mm, 100mm & 50mm.
Bottom Left: Tool-free Coupler 100mm.
Bottom Right: Express Waterfall Outlet 100mm.



Key Features

- Fully enclosed, halogen free and flame retardant design
- Integrated bend radius control helps maintain fibre integrity
- Comprehensive component range
- Available with or without covers
- Tool free, click fit modular system
- Easily scalable design allows for future expansion

Technical Diagram

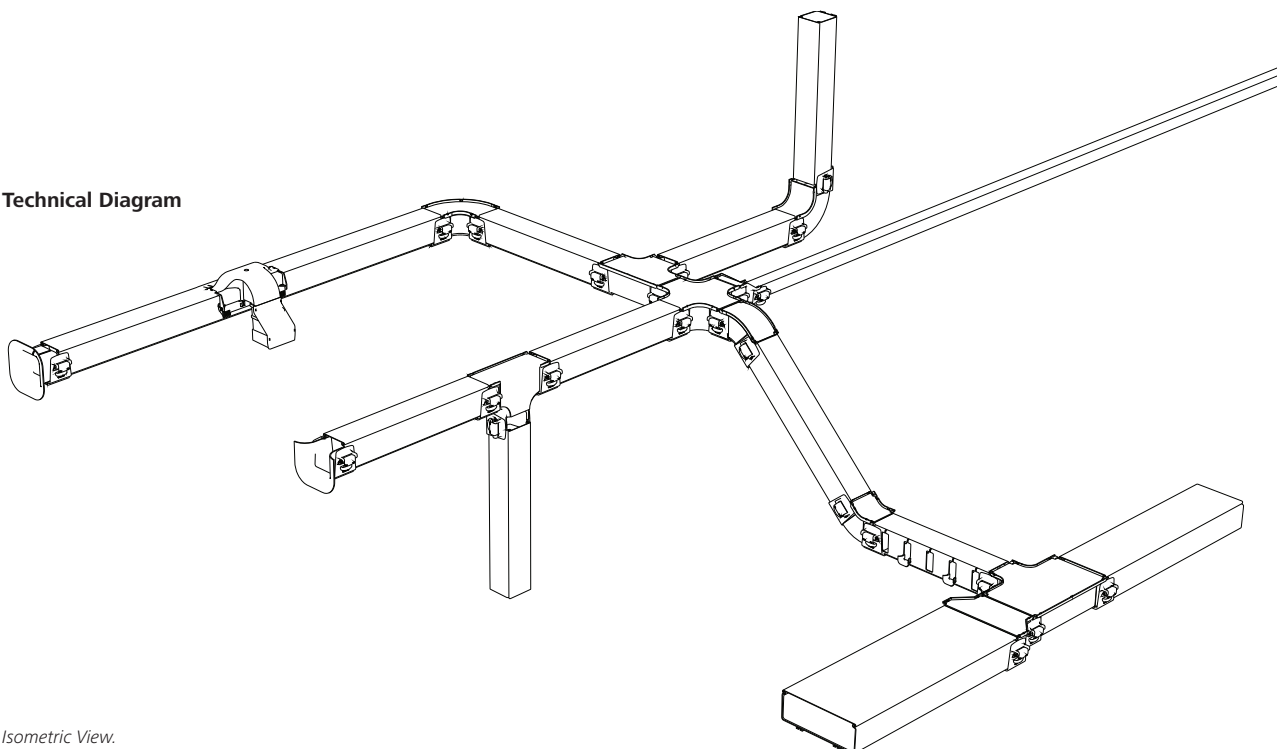

Isometric View.

Your local partner, wherever you are



Contact us

Scan the QR code or click the link to go to our website for country contact details.

[HellermannTyton.com/company/worldwide](https://www.HellermannTyton.com/company/worldwide)



HellermannTyton

HellermannTyton Data Ltd – UK

Waterside House,
Edgar Mobbs Way
Northampton NN5 5JE
Tel.: +44 1604 707 420
Email: sales@htdata.co.uk
www.htdata.co.uk